

## Requirements for a Shed Maximum 12' x 16'

### Submit:

1. Shed Worksheet or 2 set of drawings see requirements of the drawings below
2. Provide Roof Truss layout and design if manufacture Trusses

### Note:

Hand built trusses are not allowed. If rafter framing you must meet the requirements under NBC 9.23.13 "Roof and Ceiling Framing"

### Note:

Premanufactured sheds must still meet all the same requirements for site built accessory buildings

### Note:

If the shed exceeds 12' x 16' use detached garage form.

### Drawing Requirements:

#### **Site plan**

Building address; street names; size of the site; size of the building(s); location of the building(s) in relationship to the property lines and other buildings; setback distances of building(s) from front, rear and sides of the property on all sides; legal description; easements.

#### **Foundation plan**

Type, number and spacing of skids or treated foundation details and type of gravel base.

#### **Floor Systems**

Type, size and spacing of joists and decking. Include any cantilever details

#### **Cross section c/w details**

Cut through views of the building; lists of all materials used for construction including, roofing, wall studs, wall sheathing, siding, siding membrane and lintels.

#### **Roof Trusses**

Complete engineered design and layout of all engineered roof trusses.

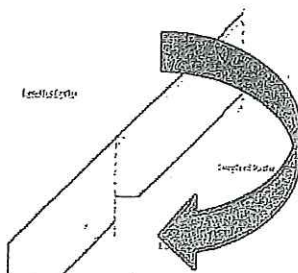

Rafter framing requires a shaped bottom

B&D Contract Service ,Box 297 Gull Lake ,Sk. ,S0N 1A0 Ph. 306-672-7543  
 Building Inspection & Home Inspection  
 Service

# Shed Worksheet

Form#  
2010-042

Client Information	
Name	
Address	
Phone#	
Email	

Sheet Size	
Width	Length

Skid/Decking Spacing			
Type	Thickness /orientation	Skid Spacing (in) on-center	Cantilever (inches)
Ply or OSB	5/8"	16"	0"
Ply or OSB	3/4	24"	0"
2x4	On Flat	32"	0"
2x4-16" o/c	On Edge	72"	0"
2x6	On Flat	32"	12"
2x6-16" o/c	On Edge	9'4"	12"
2x8	Of Flat	48"	0"
2x8-16" o/c	On Edge	12'4"	16"
2x8-24" o/c	On Edge	10'9"	16"
2x10	On Flat	48"	0"
2x10 16" o/c	On Edge	14'6"	24"
2x10-24" o/c	On Edge	13'6"	24"

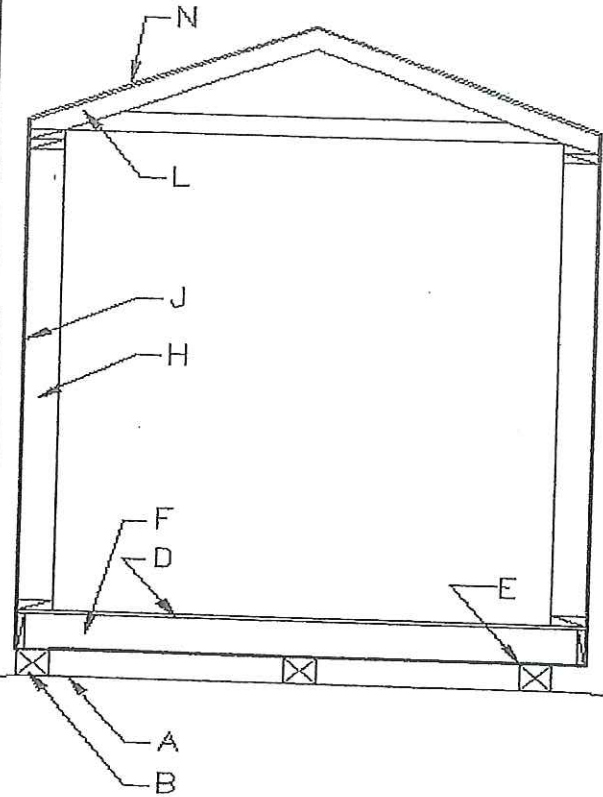

Detail Details (see picture above) Fill in all detail spaces		
A	Gravel Base sloped	Shed must have a sloped gravel base
B	Type of skids e.g. 6x6, 4x4	
C	Number of Treated Skids	
Note	All wood material that is not treated must be 6" from ground	
D	Plywood or decking type and thickness	
E	Joist cantilever distance from edge of skids	
F	Joist Type: e.g. 2x6, 2x8 2x10, Spruce or Fir	
G	Joist Spacing: 16", 24"	
H	Wall Type: e.g. 2x4, prebuilt truss	
I	Stud or Truss spacing	
J	Wall Sheathing type	
K	Size and plies: Lintels above openings	
L	Roof rafter size if not trusses e.g. 2x4, 2x6	
Note	Rafters must be shaped, have a gullet plate at top and ceiling joist to hold the walls in. They must meet all requirements of NBC 9.23.13 "Roof and Ceiling Framing"	
N	Type of Roofing material	
O	Type of membrane (tar paper) and siding	